

II^e International Snowplow Championship.

In the framework of the XIV^e International Winter road congress Viability of the World Road Association (PIARC), which will be held in Andorra-la Vella, will have place the 2nd International Championship of snowplow in the continuation of that organized in Quebec in 2010. The organization of this event will be organised by the department of the Conservation and the Exploitation of roads (COEX) depend on the Ministry for the economy and the Territory in Andorra.

This friendly competition between snowplow drivers coming from the whole world consists in an evaluation of their driving competences on a skill-testing course and their knowledge on safety and mechanics.

CONTESTANTS

Each country taking part could register a maximum of 4 representatives coming from the public or private sector.

In order to select a maximum of ten drivers for the final course, all the participants will have to pass from the eliminatory tests.

THE EVALUATION

The evaluation will be made up of a test of safety in order to evaluate mechanical knowledge and of a test of control on a course of skill.

At the time of the various tests, the vehicle used will be a UNIMOG U400, diesel truck with automatic transmission with a 4 X 4 traction of a power from approximately 230 CV provided with a tilting frontal blade and a bucket.

The technical characteristics of the vehicle is presented in appendix 2.

1) MECHANICAL INSPECTION

This specific test will be used to evaluate knowledge of the competitors concerning the safety requirements. Each driver will have to check its vehicle and to raise the anomalies.

2) DRIVING TEST

This test will make it possible to evaluate the skill of the driver on a course comprising several difficulties of control: turns on the right and on the left, stops, obstacles to be avoided. The course of each competitor will be timed in order to decide between them in the event of equality. If the driver must face an urgency, it will be able to take a downtime to rectify this situation.

Once the announced departure, the driver will have to adopt a regular control throughout course and will not have to immobilize its truck apart from the places indicated, if not it will be penalized.

The driver will not be able to return in opposite direction to the direction designed to take again a test.

THE COURSE

This championship will be composed of two tests which will take place on the circuit of Grandvalira.

Located at the collar of Envalira to approximately 28 kilometers of the general road 2 (CG2), at an altitude of 2 200 m, this circuit is used during the winter, for car races on snow.

The organizers of the II^E International Championship of snowplow thank the «Automobile club of Andorra», ACA, for its co-operation and the possibility of carrying out these tests on their circuit.

The layout of the course is in appendix 1, however the organizers reserve the right to modify these elements where necessary.

GENERAL INFORMATION

In spite of the presence of voluntary and the people assigned to safety, each competitor is responsible for its own person, when it is on or near the course.

With the collar of Envalira in February, the temperatures are cold and can reach - 30 °C. It is responsibility for each driver to outside use suitable clothing at the time of the competition.

In the event of extreme weather conditions being able to affect the safety of the participants, the witnesses or voluntary, the Office of Andorra 2014 reserves the right to defer or cancel the contest.

During the competition, any behavior considered to be dangerous or unacceptable by the judges or the Steering Committee of the second International Championship of snow-plow will involve the disqualification of the faulty competitor.

Each inscription will have to be validated by the first PIARC delegate of the country from which the driver comes. It is also with this one that will be sent the access codes for the inscription on line of the drivers and the access to the official payments. The drivers which will try to be registered directly will be refused and directed towards their first deputy.

The number of participants being limited to 40, with a maximum of 4 drivers for each Member State, the first registered voters will have the priority if the number of inscriptions exceeds the fixed limit.

The inscription with the International Championship of snow-plough gives right to:

- the participation the International Championship proof of snow-plow
- the visit of the exposure throughout the duration of the congress with a free access coffee Internet and the breakfast
- the participation in the opening ceremony of the congress on Tuesday February 4, 2014
- the participation in the meal of the drivers having taken part in the International Championship of snow-plow the evening on Wednesday February 5, 2014
- the participation in the closing session of the congress of Friday February 7 2014

The program of accompanying persons is the same one as that of the congress participants and is accessible on official Internet site from XIVe Congrès International of winter viability.

The provisional program of the course of the activities at the time of the International Championship of snow-plough is with appendix 3 of this document

APPENDIX 1
EXAMPLE OF COURSE

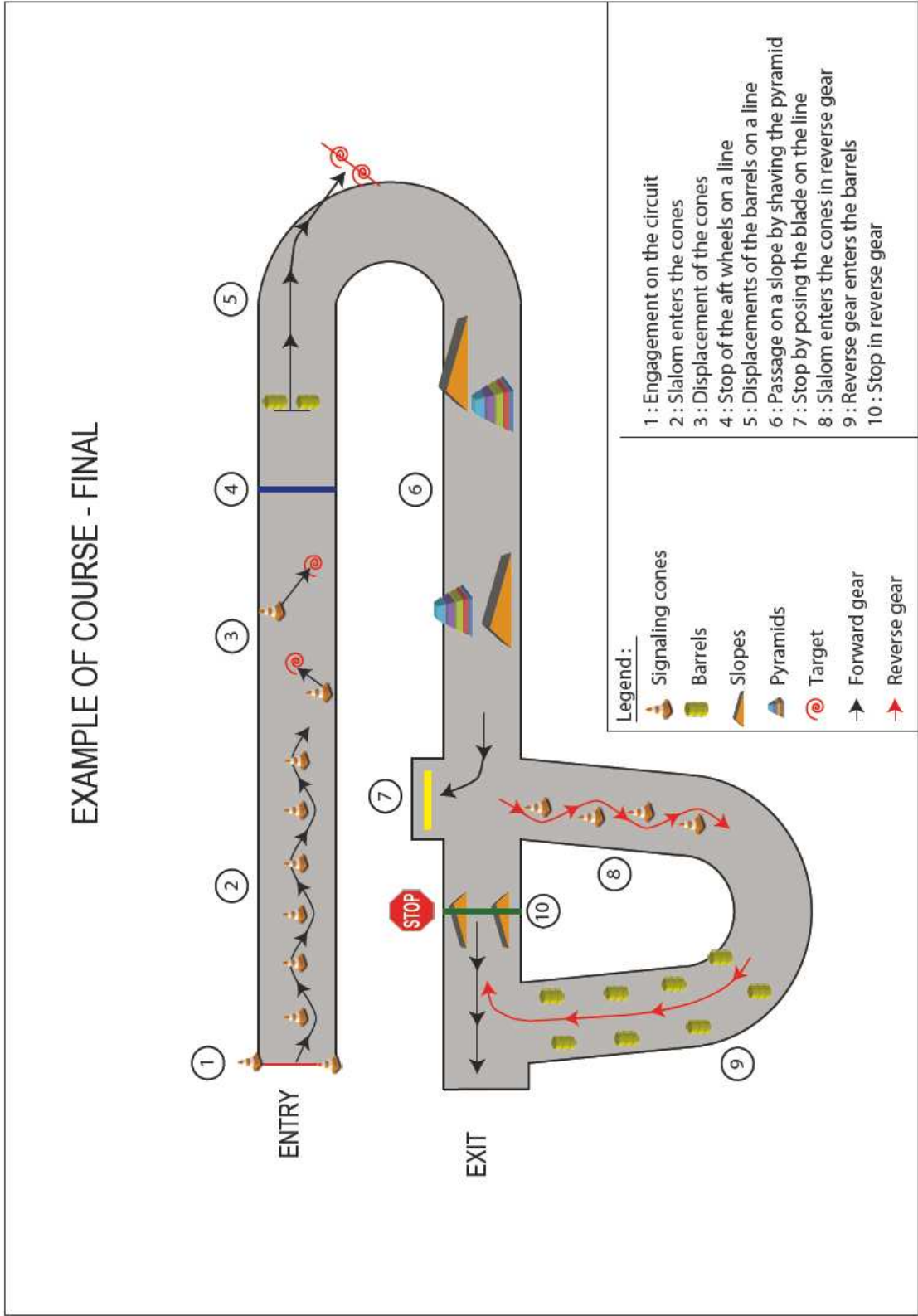

APPENDIX 2
CARD-INDEX TECHNICAL

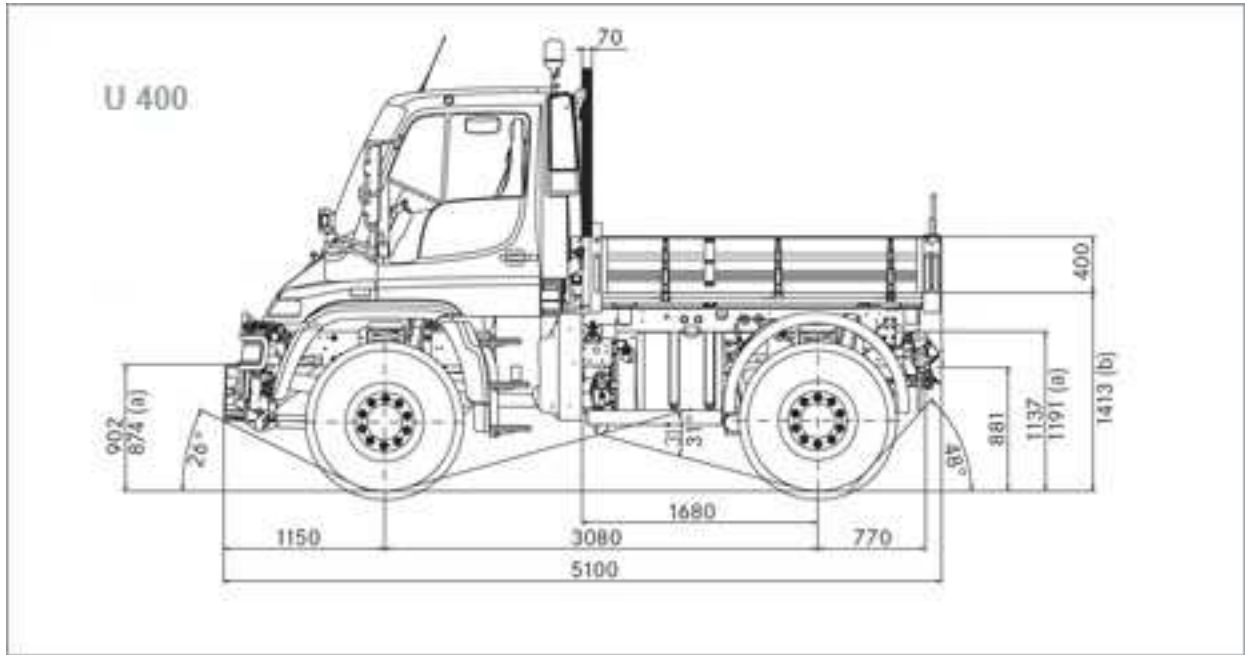

APPENDIX 3
PROVISIONAL PROGRAM

Program of the II^E International Championnat of snow-plow

Tuesday February 4, 2014

12.h 30 : Transfer of the drivers on the Grandvalira circuit
13 h : lunch
14 h 30 - 18 h 30 : qualifying heats

Wednesday February 5, 2014

08 h 30 : Transfer of the drivers on the Grandvalira circuit
09 h 30 : qualifying heats
13 h : Lunch
13 h 30 : Transfer of the congressmen on the Grandvalira circuit
14 h 30 – 18 h 30 : Demonstration of the equipment and finale of the II^E
International Championship of snow-plow for the handing-over of the trophy of
the victory
21 h 00 : Diner

4. Stop of the aft wheels on a line

5 % - 50 points

The participant will have to stop the aft wheels of his truck on the level of the line traced on the ground. The totality of the test will have to be carried out moving front. Only the first immobilization of the vehicle will be taken into account. Measurement will be taken between the axis of the aft wheels and the line.

Scoring:

From 0 to 100 mm	50 points
From 101 to 200 mm	30 points
From 201 to 400 mm	10 points
More than 401 mm	0 point

5. Displacements of the barrels

7 % - 70 points

The participant will have to move the barrels present on the course in order to bring it to more close to the line located out of the course.

Attribution of the points by barrel:

From 0 to 200 mm	35 points
From 201 to 400 mm	25 points
From 401 to 600 mm	15 points
More than 601 mm	0 point

6. Passage on a slope by shaving the pyramid

15 % - 150 points

The participant will have to pass on the slope located on the right then on the left while shaving at more close the pyramid, while making fallen the maximum of elements present on the table (without the touch), with the blade of the truck.

Scoring by pyramid:

A number of remaining elements: 0	75 points
A number of remaining elements: 1	65 points
A number of remaining elements: 2	50 points
A number of remaining elements: 3	30 points
A number of remaining elements: 4	5 points
A number of remaining elements: 5	0 points
Count touched	0 points for the pyramid
Wheels out of the slope	0 points for the pyramid

7. Stop by posing the blade on the line

5 % - 50 points

The participant will have to stop his vehicle by posing the front blade on the line. Only one operation will be authorized and taken into account. Luminous and sound witnesses will activate themselves in the event of success.

Scoring:

The blade touches the line	50 points
The blade does not touch the line	0 points



8. Slalom enters the cones in reverse gear **10 % - 100 points**

The participant will slalom between the cones in reverse gear. The stop during this test will result in a loss of points.

Scoring:

Contact with one or more cones - 25 points per cone
Immobilization of the truck during the test - 30 points per stop

9. Reverse gear enters the barrels **6 % - 60 points**

The participant will have to move back by avoiding the barrels.

Scoring:

Contact with one or more barrels - 10 points per barrel
Immobilization of the truck during the test - 15 points per stop

10. Stop in reverse gear **8 % - 80 points**

The participant will have to go up on the two slopes envisaged for this purpose and to stop the trailer of his vehicle as close to the barrier as possible without touching it. Only the first stop will be taken into account.

Scoring:

From 0 to 150 mm	80 points
From 151 to 200 mm	70 points
From 201 to 250 mm	55 points
From 251 to 300 mm	30 points
From 301 to 350 mm	10 points
More than 351 mm	0 points
Contact with the barrier	0 points
Wheels out of the slopes	0 points for the test

Speed **10 % - 100 points**

Each participant will be timed during the totality of the course of skill.

Scoring:

Less than 7 minutes	100 points
From 7 minutes and 1 second at 8 minutes	50 points
More than 8 minutes and 1 second	0 points

NB: The Office of Andorra 2014 keeps the right to modify the tests and the grid of evaluation if it considers it necessary.